

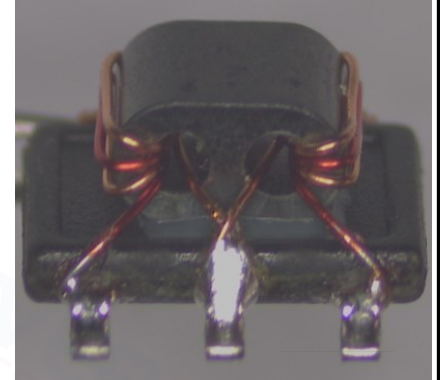

**Features::**

- ◆ Equivalent to: 33-B6030C-1221P
- ◆ 2 Way-0° Power Splitter/Combiner
- ◆ 75Ω Characteristic Impedance
- ◆ Power Input(as a splitter): 0.50W Max
- ◆ DC current: 30mA
- ◆ Operating temperature range: -40°C to +85°C
- ◆ Storage temperature range: -55°C to +100°C



**Applications:**

- ◆ For broadband and wireless communications
- ◆ For VHF/UHF receivers/transmitters and push-pull amplifiers

**Dimension Diagram (Unit:mm) :**

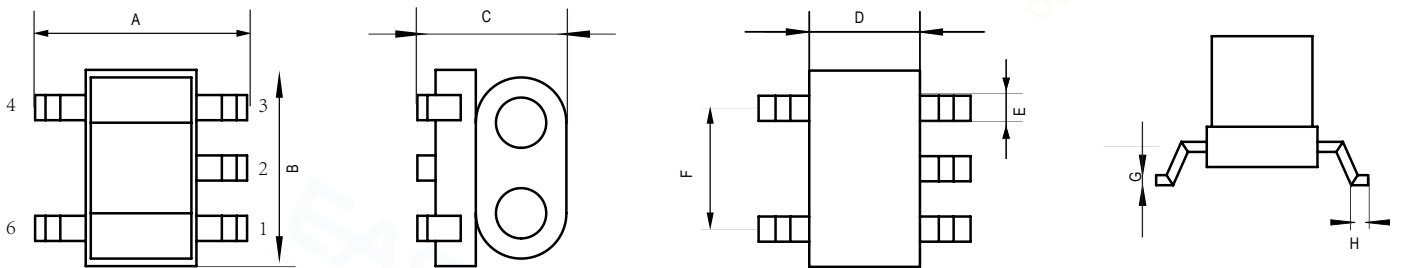

A=6.20±0.20 B=6.00±0.20 C=4.30±0.20 D=4.00±0.20 E=0.60±0.10 F=4.00±0.10 G=0.25±0.10 H=0.50±0.10

**Electrical structure:**

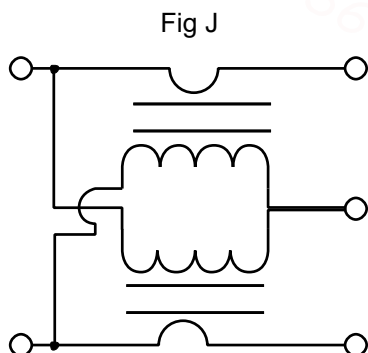

**Recommended layout:**

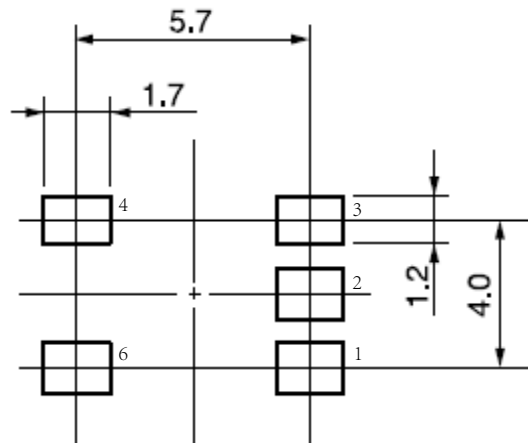

**Pin configuration:**

| Pin No. | Function               |
|---------|------------------------|
| 1       | Input                  |
| 2       | Ground                 |
| 3       | Output1                |
| 4       | Ouput 2                |
| 6       | External 150Ω Resistor |

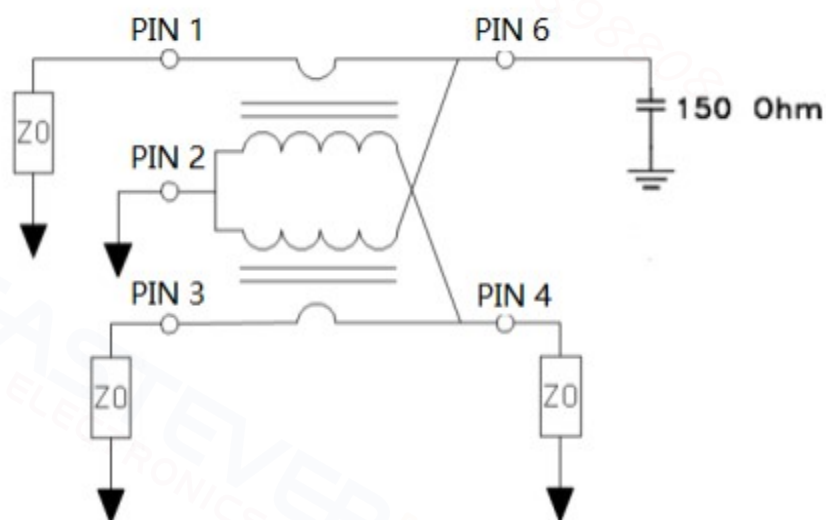
**Application circuit :**

**Electrical Specifications:** TA=25°C Z0=75Ω

| Parameter            | Test Conditions | Units | Min  | Typ  | Max |
|----------------------|-----------------|-------|------|------|-----|
| Main line Loss(out1) | 5-2400MHz       | dB    | —    | 1.0  | 4.0 |
| Main line Loss(out2) | 5-2400MHz       | dB    | —    | 1.2  | 4.0 |
| Input Return Loss    | 5-2400MHz       | dB    | 5.0  | 12.5 | —   |
| Output 1 Return Loss | 5-2400MHz       | dB    | 3.0  | 15.0 | —   |
| Output 2 Return Loss | 5-2400MHz       | dB    | 2.0  | 20.0 | —   |
| Isolation            | 5-2400MHz       | dB    | 10.0 | 15.0 | —   |

### Main line Loss(port1)

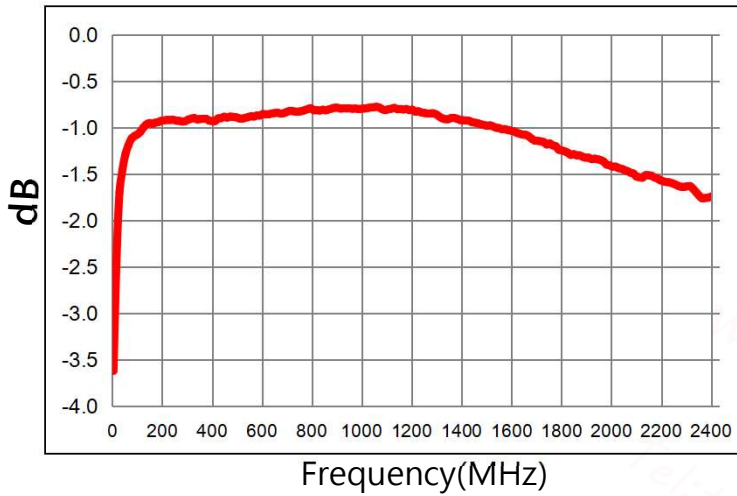

### Main line Loss(port2)

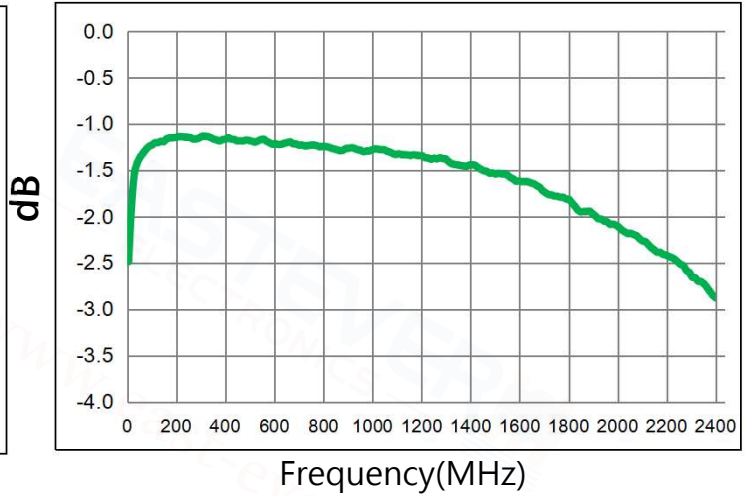

### Input Return Loss(pin1)

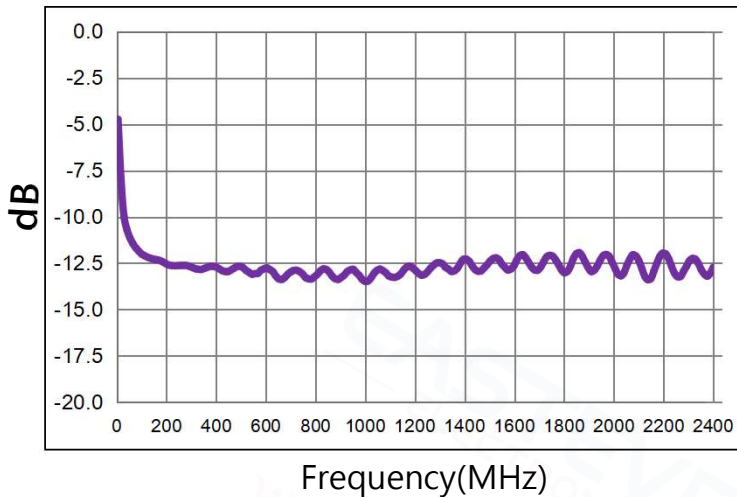

### Output 1 Return Loss(pin3)

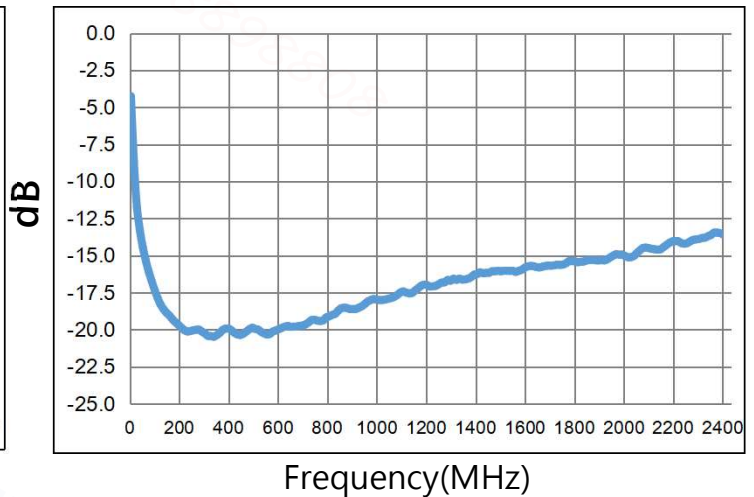

### Output 2 Return Loss(pin4)

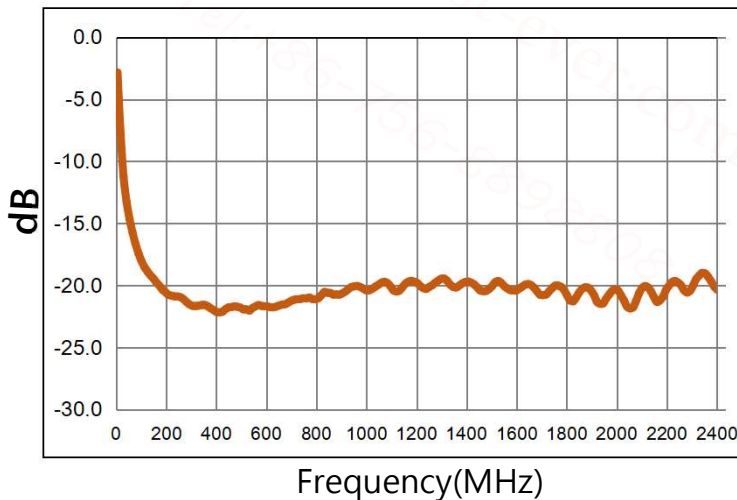

### Isolation(pin4-3)

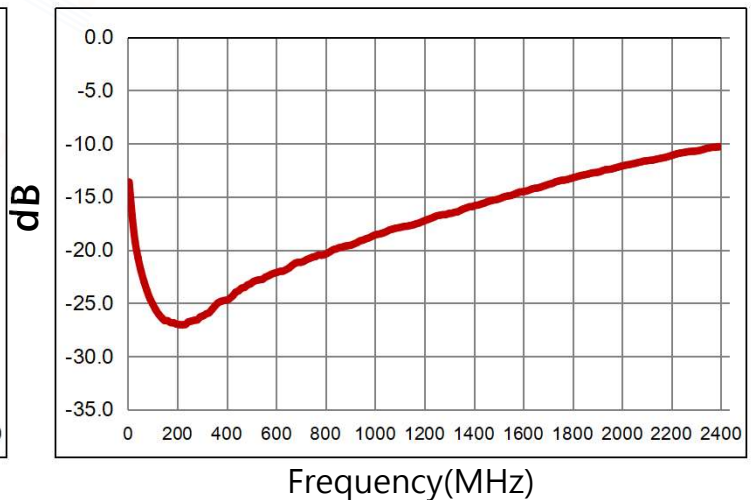

**Recommended Soldering Temperature Graph:**

**Typical RoHS Reflow Profile**

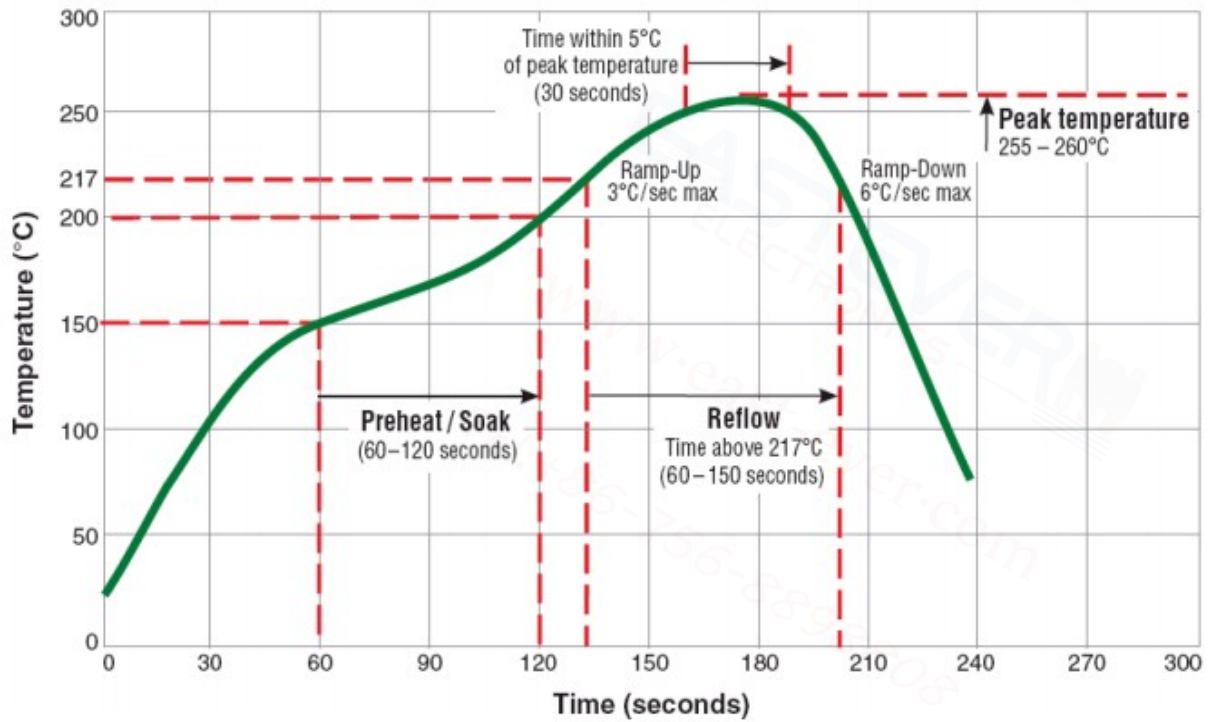

**Packaging Dimension For Caeier Tape(UNIT:mm):**

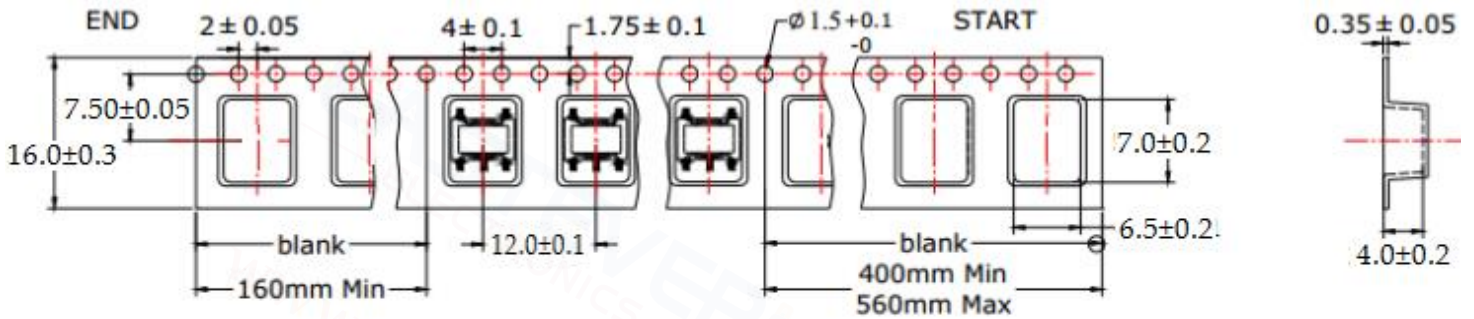

|                                     |
|-------------------------------------|
| <b>QUANTITY</b>                     |
| 1000PCS/Reel                        |
| 3Reels/Middle Carton Middle Carton: |
| 4 Middle Cartons/Big Carton         |
| 12000PCS/ Big Carton                |



|                  |     |      |      |      |
|------------------|-----|------|------|------|
| <b>SPEC</b>      | 8   | 12   | 16   | 24   |
| <b>DIM A±0.1</b> | 8.5 | 12.5 | 16.5 | 24.5 |
| <b>DIM B±0.1</b> | 2.3 | 2.3  | 2.3  | 2.3  |
| <b>DIM C±0.1</b> | 100 | 100  | 100  | 100  |

