

LAN Transformer

100/1000 BASE-T PG72K04 G Equivalent to HX5014NL-12

REV: 0

A. MECHANICAL(unit:mm)

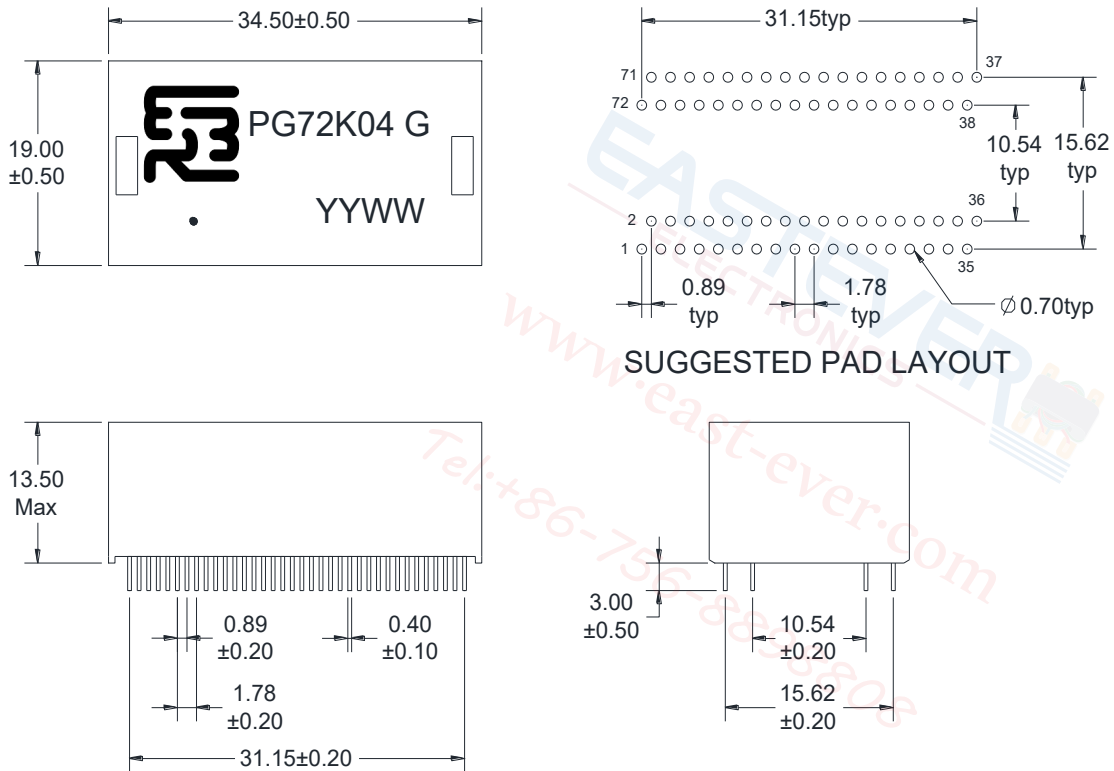

B. SCHEMATICS

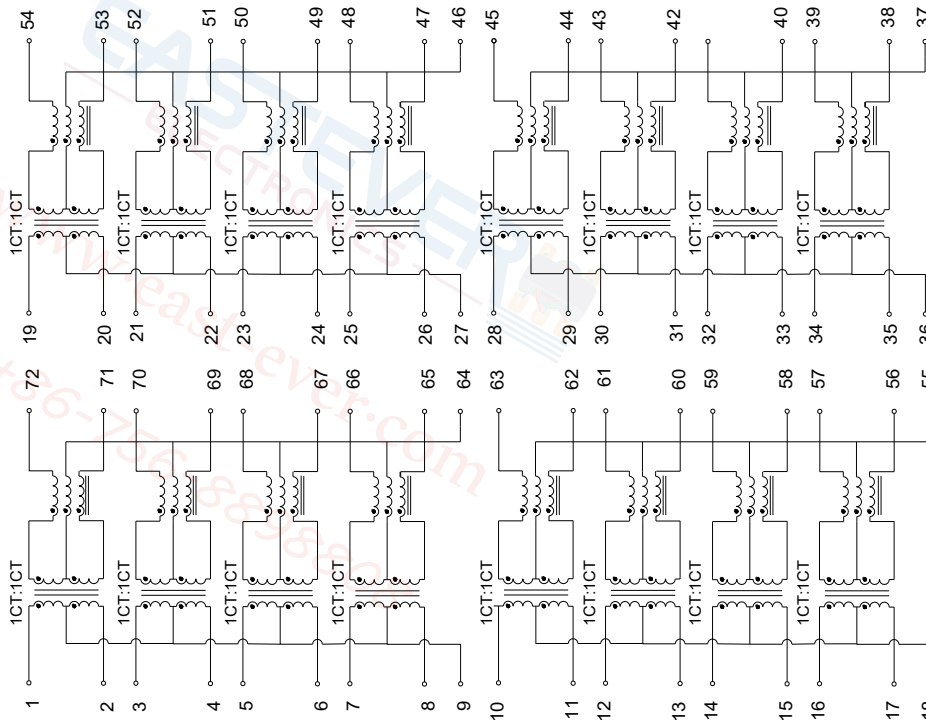

LAN Transformer

100/1000 BASE-T PG72K04 G Equivalent to HX5014NL-12

REV: 0

C. ELECTRICAL SPECIFICATIONS @25°C

1. OCL: 350uH Min @ 100KHz, 0.1V 8mA DC BIAS
2. Leakage Inductance: 0.5uH Max @ 100KHz, 0.1V
3. DCR: 1400mΩ Max
4. Turns Ratio: 1CT:1CT±5%
5. Insertion Loss: -1.2 dB Max @ 0.5-1 MHz
-0.2-0.002*f^{1.4} dB Max @ 1-125 MHz
6. Return Loss: -16 dB Min @ 1-40 MHz
-10+20*log (f/80) dB Min @ 40.1-100 MHz
7. Cross Talk: -30 dB Min @ 1-100 MHz
8. Common Mode Rejection: -30 dB Min @ 1-100 MHz
9. Isolation Hipot: 1500VAC 1mA 60S
10. Operating temperature 0°C to +70°C
11. Storage temperature -40°C to +85°C

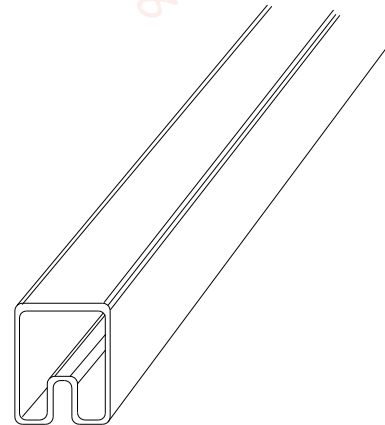
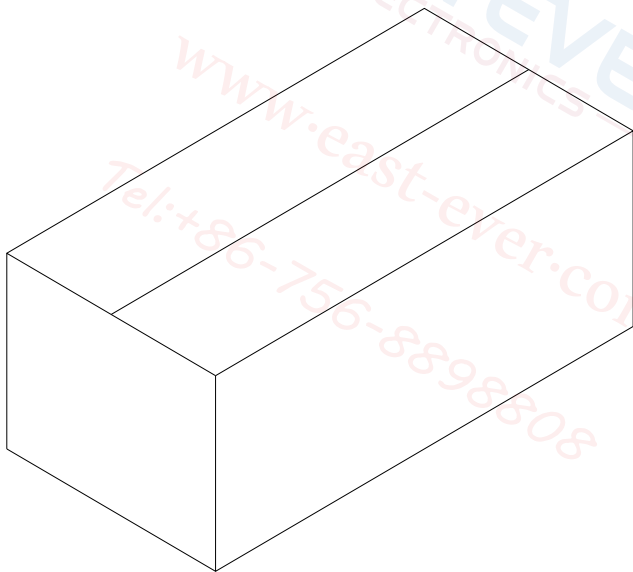

Carton: L550*W255*H195mm

Package Quantity:

One Tube=14Pcs

One Carton=14*108=1512Pcs