

# LAN Transformer

100/1000 BASE-T SG48001G Equivalent to PM6C-2004F

REV: 0

## A. MECHANICAL (unit:mm)

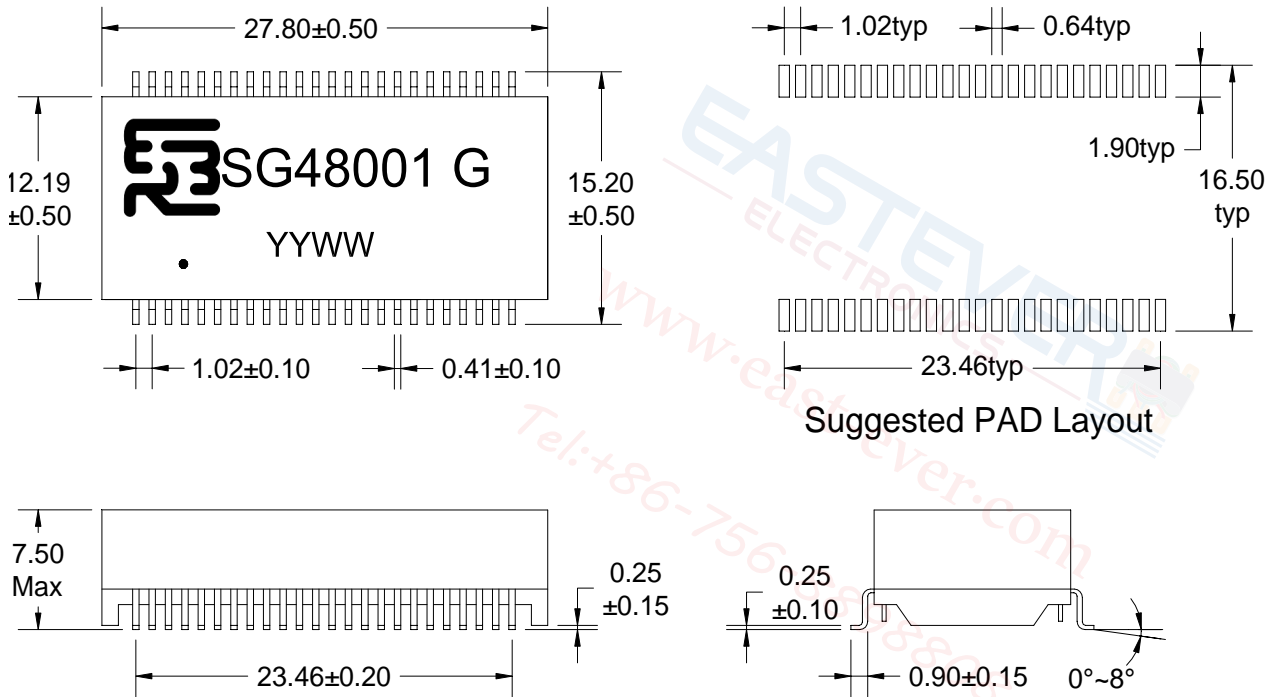

## B. SCHEMATICS

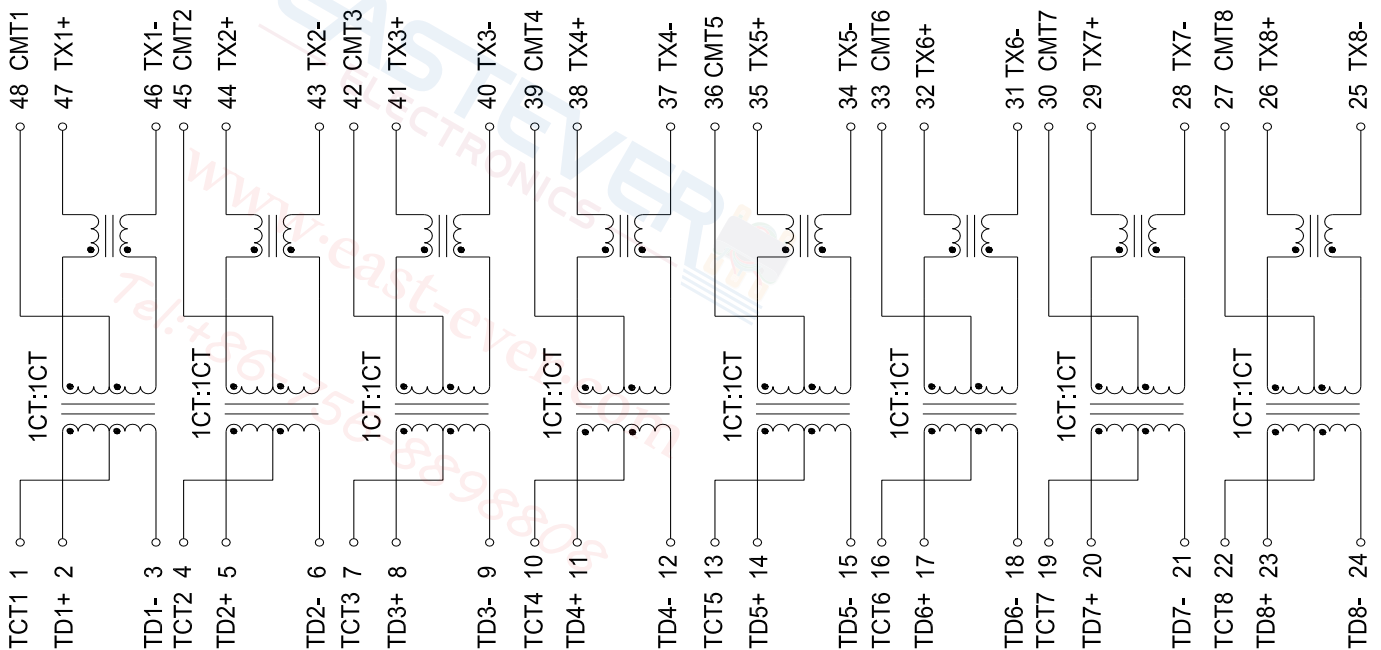

# LAN Transformer

100/1000 BASE-T SG48001G Equivalent to PM6C-2004F

REV: 0

## C. ELECTRICAL SPECIFICATIONS @25°C

1. OCL: 350 uH Min @ 100 KHz, 0.1V with 8mA DC BIAS
2. Leakage Inductance: 0.5uH Max @ 100KHz, 0.1V
3. DCR: 1400mΩ Max
4. Turns Ratio: 1CT:1CT±5%
5. Insertion Loss: -1.1 dB Max @ 1-100 MHz
6. Return Loss: -18 dB Min @ 1-30 MHz
  - 14.4 dB Min @ 40 MHz
  - 13.1 dB Min @ 50 MHz
  - 12 dB Min @ 60-80 MHz
  - 10 dB Min @100 MHz
7. Cross Talk: -30 dB Min @ 1-100 MHz
8. Common Mode Rejection: -30 dB Min @ 1-100 MHz
9. Isolation Hipot: 1500VAC 1mA 60S
10. Operating temperature 0°C to +70°C
11. Storage temperature -20°C to +125°C

## D. PACKAGE INFORMATION

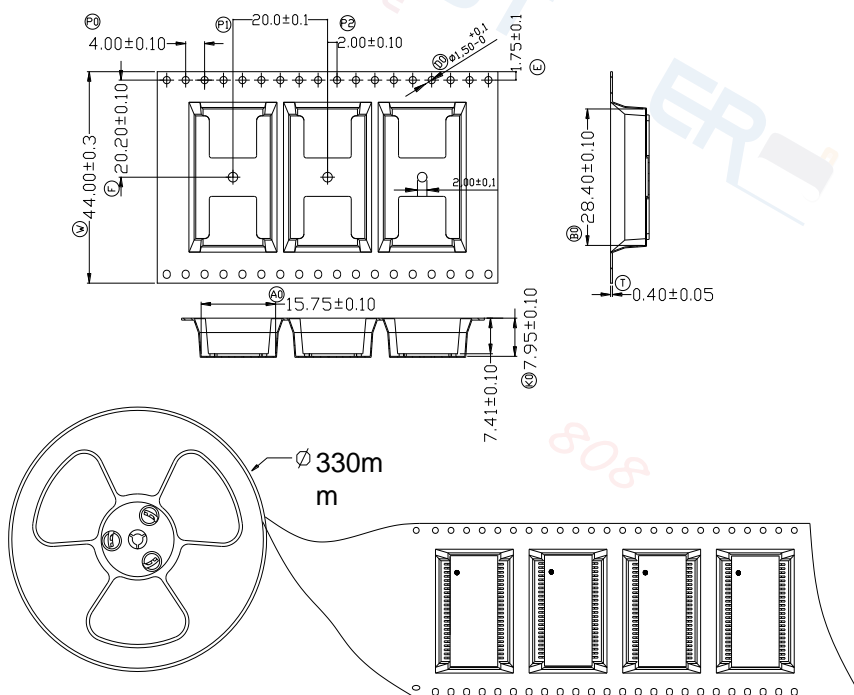

Package Quantity:

One Reel=350Pcs

One Inner Carton=350\*2=700Pcs

One Export Carton=700\*2=1400Pcs